

N^o 15,769



A.D. 1915

Date of Appliation, 8th Nov., 1915

Complete Specification Left, 8th May, 1916—Accepted, 12th Oct., 1916

PROVISIONAL SPECIFICATION.

Improvements in Valve Gear for Locomotive and other Steam Engines.

I, HERBERT NIGEL GRESLEY, of Avenue House, Doncaster, Yorkshire, Locomotive Engineer, do hereby declare the nature of this invention to be as follows:—

5 This invention relates to valve gear for locomotive or other reversible steam engines having three cylinders the piston rods of which are connected with cranks set at suitable angles, for instances 120°, to each other.

10 The invention consists principally in providing connections between the valve spindles or rods of two outer cylinders (which may be situated outside the engine frame in the case of a locomotive) and the valve spindle or rod of an intermediate or central cylinder whereby the movements given to the valve spindles of the outside cylinders effect the requisite movements of the valve spindle of the intermediate cylinder so that no independent or separate valve gear,—such, for instance as that usually employed for each valve of a two
15 cylinder engine,—is required for actuating the distribution valve of the intermediate or central cylinder.

Further in one arrangement according to this invention, for the purpose above-mentioned, I employ two rods or levers of unequal length and arranged transversely of the engine, preferably so as to work in horizontal planes one above the other, these rods or levers being operatively connected one with the
20 other and with the valve spindles of the three cylinders. Each of these rods is pivotally connected, for instance by pins and links, at or adjacent its outer end to the valve spindle of the adjacent outer cylinder, and the longer rod or lever pivots, intermediate of its length, on a fixed point at or near the centre line of the engine. The shorter rod or lever pivots intermediate its length on or
25 near that end of the longer lever opposite to the end connected (as above-mentioned) to the valve spindle of one of the outer cylinders, the said short rod or lever thus being a floating lever. The valve spindle of the intermediate or central cylinder is pivotally connected, for instance by a link and pins, to the
30 inner end of the aforesaid shorter rod or lever.

As an alternative, instead of the above-mentioned arrangement of rods or levers, a combination of rocking shafts and levers may be employed. For instance, in one arrangement adapted for a locomotive with valve chest situated on one side of the central or intermediate cylinder, two rocking shafts of unequal length may be arranged transversely of the engine, in suitable fixed
35 bearings, each of these rocking shafts having fixed on them, at or adjacent their ends, suitable levers or cranks the levers at the adjacent inner ends of the two rock shafts being pivotally connected to a suitable sway beam or lever one end (which may be the upper end) of which may be connected with the lever or crank on the inner end of the shorter rock shaft, and the lever or crank on the
40 inner end of the longer rock shaft may be pivotally connected to the said sway

[Price 6d.]

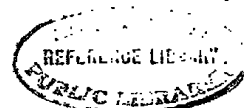

Improvements in Valve Gear for Locomotive and other Steam Engines.

beam or floating lever at a point intermediate its ends preferably at a point adjacent the end (which may be the lower end) of said sway beam which is pivotally connected, for instance by a link and pins, to the valve spindle of the intermediate or central cylinder. There may be two levers or cranks on the outer end of each of the aforesaid rocking shafts, one of which levers may be at the extreme outer end of the shaft and the other a short distance from said end this latter lever on one of the rock shafts being pivotally connected with the valve spindle of one of the outside cylinders, the corresponding lever or crank near the outer end of the other rock shaft being similarly connected with the valve spindle of the other outside or outer cylinder. The levers or cranks on the extreme outer ends of the rock shafts may be pivotally connected with the usual or any suitable valve motion employed for the valves of the outer cylinders.

Dated this 8th day of November, 1915.

JOHN P. O'DONNELL,
 Fel.Chart.Inst.P.A., M.Inst.C.E.,
 Agent for Applicant,
 Palace Chambers, Westminster, S.W.

COMPLETE SPECIFICATION.**Improvements in Valve Gear for Locomotive and other Steam Engines.**

I, HERBERT NIGEL GRESLEY, of Avenue House, Doncaster, Yorkshire, Locomotive Engineer, do hereby declare the nature of this invention and in what manner the same is to be performed, to be particularly described and ascertained in and by the following statement:—

This invention relates to valve gear for locomotive or other reversible steam engines having three cylinders, the piston rods of which are connected with cranks set at suitable angles, for instance 120°, to each other, of the kind in which the valve of the intermediate cylinder is actuated through lever mechanism by or from the valves of the two outer cylinders without the employment of an independent or separate valve gear for the valve of said intermediate cylinder.

The invention has for its object to provide a simple and efficient construction and arrangement of mechanism of the kind above referred to, such as will give to the intermediate valve its proper normal travel and correct movements at all times in the running of the engine.

The invention consists principally in the combination of a lever having a fixed pivotal point or fulcrum so arranged that such lever has a longer and a shorter arm, the longer arm being operatively connected to the spindle of the valve of one of the outer cylinders, and a second floating equal-armed lever or sway beam having one arm operatively connected to the spindle of the valve of the other outer cylinder and its other arm operatively connected to the spindle of the valve of the intermediate or centre cylinder, this second equal-armed lever or sway beam being pivotally connected at its centre to the end of the shorter arm of the first-mentioned lever, the position on the engine frame-work of the fixed pivotal point of the first mentioned lever and the length of the respective arms of said lever being such that the movements of the valves of the outer cylinders give, through the said two levers, movement correct as to time and travel to the valve of the intermediate or centre cylinder. The levers

Improvements in Valve Gear for Locomotive and other Steam Engines.

may be simple levers arranged to work in horizontal planes one above the other, and assuming the length of the travel of the intermediate valve to be the same as that of each of the outer valves, the lever pivoting about a fixed point is a "two-to-one" lever; the said "two-to-one" lever however may be in the form of a rock shaft having half-cranks or arms of the required lengths fixed thereon at opposite ends, in which case, the connection of the arm of the floating lever to the respective outer valve spindle is also through a rock shaft having suitably positioned equal length arms fixed thereon, connected respectively to the said valve spindle and the floating lever, which latter lever then works in a vertical plane.

In the case of the arrangement according to this invention in which the levers work in horizontal planes, each of the levers is pivotally connected, for instance by pins and links, at or adjacent its outer end to the valve spindle of the adjacent outer cylinder, and one lever pivots, intermediate of its length, on a fixed point at or near the centre line of the engine. The other lever pivots intermediate its length on or near that end of the first mentioned lever opposite to the end connected (as above-mentioned) to the valve spindle of one of the outer cylinders, the said other or second mentioned lever thus being a floating lever. The valve spindle of the intermediate or central cylinder is pivotally connected, for instance by a link and pins, to the inner end of the said second mentioned lever.

The above-mentioned alternative arrangement according to this invention in which a combination of rocking shafts and levers is employed, is more particularly adapted for a locomotive with the valve chest of the central or intermediate cylinder situated on one side of such cylinder, and in such arrangement two rocking shafts of unequal length may be arranged transversely of the engine, in suitable fixed bearings, each of these rocking shafts having fixed on them at or adjacent their ends, suitable levers or cranks, the levers at the adjacent inner ends of the two rock shafts being pivotally connected to a suitable sway beam or lever one end (which may be the upper end) of which is connected with the lever or crank on the inner end of the shorter rock shaft, and the other end of which is pivotally connected, for instance by a link and pins, to the valve spindle of the intermediate or central cylinder, the lever or crank on the inner end of the longer rock shaft being pivotally connected to the centre of said sway beam or floating lever. There may be two levers or cranks on the outer end of each of the aforesaid rocking shafts, one of which levers may be at the extreme outer end of the shaft and the other a short distance from said end this latter lever on one of the rock shafts being pivotally connected with the valve spindle of one of the outside cylinders, the corresponding lever or crank near the outer end of the other rock shaft being similarly connected with the valve spindle of the other outside or outer cylinder. The levers or cranks on the extreme outer ends of the rock shafts may be pivotally connected with the usual or any suitable valve gear or valve motion mechanism employed for the valves of the outer cylinders. The lever on the longer rock shaft connected to the outer cylinder is longer than the lever on the inner end of said rock shaft connected to the centre of the sway beam.

In order that the invention may be more clearly understood and readily carried out in practice, two embodiments (by way of example) of the invention will now be described with reference to the accompanying drawings in which,—

Fig. 1 is a side elevation, more or less diagrammatic, illustrating one embodiment of this invention as applied to a locomotive engine,

Fig. 2 being a plan view, and Fig. 3 an end elevation of the embodiment of the invention shewn in Fig. 1.

Fig. 4 is a similar view to Fig. 1 but shews an alternative embodiment of the invention.

Figs. 5 and 6 are respectively a plan view and an end elevation of the embodiment of the invention shewn in Fig. 4.

Improvements in Valve Gear for Locomotive and other Steam Engines.

Like reference numbers indicate corresponding parts in the several figures of the drawings.

Referring to Figs. 1, 2 and 3, 1 indicates the driving wheels of a locomotive engine, 2 being the driving crank axle having the outside cranks 3, 3^a, coupled in the usual or any suitable manner with the piston rods of the two outer or outside cylinders 4 and 5 respectively. 6 is the intermediate or central crank on the axle 2 the piston rod of the intermediate or inner cylinder 7 being connected to the crank 6 in the known or any suitable manner.

8 is the valve, of the left-hand (outer) cylinder 4 (Fig. 2) 9 the valve of the right-hand (outer) cylinder 5, and 10 the valve of the central or intermediate cylinder 7, these valves, in the example shewn, being piston valves. Ordinary D-slide valves might be employed if desired. The valves 8, 9 and 10 are arranged to work in valve chambers or casings (not shewn) of the usual or any suitable kind.

The valve motion mechanism or valve gear illustrated, more or less diagrammatically, is the well known Walschaert's valve gear, a set of which is as usual provided in connection with each of the valves 8 and 9. Valve gears of the well known Joy or Stephenson types, or of other suitable type might however be employed in place of the Walschaert's gears illustrated. In the Walschaert's valve gear illustrated 11 indicates the eccentric on the main crank shaft 2, 12 the eccentric rod connected to the eccentric 11 and to the slot link 13, 14 the radius rod a pin or roller on one end of which works in the slot of the link 13 the other end of the said rod being operatively connected with the combination lever 15 which, through the link 16 and arm 17, is operatively connected with the cross-head 18 on the piston rod of the outside cylinder to which the valve gear applies, for instance the cylinder 4, (the valve gear of the cylinder 5 being in all respects identical to that of the cylinder 4), the combination lever 15 being also operatively connected to the spindle of the valve 8 appertaining to the cylinder 4.

The various parts of the valve gear above described and shewn more or less diagrammatically, would be all constructed, combined and adapted to operate in the well known manner as in such valve gears now employed.

The apparatus or mechanism according to the embodiment of my invention illustrated in Figs. 1, 2 and 3 of the drawings will now be described, as follows:—

19 indicates portions of the underframe of the engine and 20 a transverse bar or support suitably secured to the portions 19 of the underframe. 21 and 22 are the hereinbefore mentioned levers of unequal length, the relatively long lever 22 being mounted on a pivot 23, which has its bearing in a hole or suitable bearing in the cross-bar 20, so as to be capable of having a rocking motion, the pivot 23 forming the centre or fulcrum on which the lever 22 rocks. The outer end of the lever 22 is, as shewn, pivotally connected to one end of a link 24 the opposite end of which is pivotally connected to the spindle 25 of the valve 9, and the inner end of the lever 22 is pivotally connected, by the pin or pivot 26, to the centre of the relatively short lever 21; the inner end of the lever 21 is pivotally connected at 27 to one end of the link 28 the other end of which is pivotally connected at 29 to the spindle 30 of the valve 10, and the outer end of the said lever 21, which is a floating lever, is pivotally connected, at 31, to one end of the link 32 the other end of which is pivotally connected, at 33, to the spindle 34 of the valve 8.

The construction and arrangement of the various parts of the apparatus according to this invention, as above described with reference to Figs. 1, 2 and 3 of the drawings, are such that in the working of the engine the proper movements are given to the valve 10 of the central or intermediate cylinder 7, for admitting steam to and exhausting steam from the said cylinder 7 at the proper times, by the movements given to the levers 21 and 22 by the working of the valves 8 and 9 of the outer cylinders 4 and 5. Further, the usual

Improvements in Valve Gear for Locomotive and other Steam Engines.

adjusting movements given to the valves 8 and 9 by the adjustments or notching up of the valve gears of these valves (by means of the usual reversing lever operable by the engine-man), are transmitted, through the levers 21 and 22, to the valve 10 of the central cylinder 7 so that the proper adjustments of the valve 10 are also obtained.

Referring now to the alternative construction and arrangement illustrated in Figs. 4, 5 and 6 of the drawings, in this construction and arrangement, 35 and 36 are the hereinbefore mentioned rocking shafts of unequal length, the relatively long shaft 36 being supported at or adjacent its opposite ends in suitable fixed bearings (for instance fixed to the underframe of the engine or to a suitable part secured to the underframe) 37, 38, the relatively short rocking shaft 35 being similarly supported in bearings 39, 40. As clearly shewn in Figs. 5 and 6 the shaft 36 has fixed on it levers or cranks 41, 41^a and 42 the lever 41 being pivotally connected to links 43, 43^a which are also pivotally connected as shewn to a crosshead 44 on the spindle 25 of the valve 9, and the lever 42 pivotally connected to the sway beam or floating lever 45 at a position, indicated at 45^a, between the ends of said lever. The shaft 35 has fixed on its levers or cranks 46, 46^a and 47 the lever 47 being pivotally connected at 48 to the upper end of the sway beam or lever 45 and the lever 46, pivotally connected to links 49, 49^a which are also pivotally connected to a cross-head 44^a on the spindle 34 of the valve 8. The lower end of the floating lever or sway beam 45 is pivotally connected to links 50 which are also pivotally connected to the spindle 30 of the valve 10.

The lever or crank 41^a on the shaft 36 is pivotally connected, as shewn in Figs. 4 and 6 to the combination lever 15 of the valve motion mechanism or valve gear appertaining to the valve 9 of the right-hand cylinder 5, and the lever or crank 46^a on the shaft 35 is similarly connected to the combination lever 15 of the valve gear appertaining to the valve 8 of cylinder 4. 51, Fig. 6, indicates the valve chambers or casings of the valves 8, 9 and 10, and 52, Figs. 4 and 5, indicates the ported liners usually fitted in the valve chambers.

The working of the apparatus above described with reference to Figs. 4, 5 and 6 of the drawings is the same as described with reference to the apparatus illustrated in Figs. 1, 2 and 3, except that with the apparatus shewn in Figs. 4, 5 and 6 the requisite motions of the valve 10 are transmitted to the said valve, from the valves 8 and 9, through the rocking shafts 35, 36 and floating lever or sway beam 45.

As clearly shewn in Figs. 2 and 3 of the drawings the lever 22 is a two-to-one lever the longer arm, to the right of the pivot 23 (Fig. 3), being connected with the spindle of the valve 9 and the shorter arm connected to the floating lever 21 by the pivot 26 at a point equidistant its ends; and the floating lever 21 is an equal lever its arms, to the right and left of the pivot 26, being connected respectively with the spindles of the valve 8 and 10 as hereinbefore described.

Also as clearly shewn in Figs. 1, 2, 4 and 5 of the drawings the cranks 3, 3^a and 6 are set relatively to each other on the axle 2 at an angle of 120°.

Further, as shewn in Figs. 4 and 6 of the drawings, the lever or crank 41 on shaft 36 is twice the effective length of the lever or crank 42 on the said shaft, thus providing a two-to-one lever, and the crank 42 is pivotally connected to the floating lever 45, at the point 45^a, between the ends of the said floating lever.

Variations might be made in the details of construction and arrangement of the parts of the apparatus hereinbefore described and illustrated in the drawings without departing from the main features of the invention. For instance, it is not essential that the hereinbefore mentioned levers 21 and 22 (see Fig. 3) should be of unequal length as shewn. For instance with the positions of the valves 8, 9 and 10 suitably altered the relative overall lengths of the levers 21, 22 might be suitably altered; or these levers might, if desirable, be equal in length.

I may here point out that I am aware that it has been heretofore proposed

Improvements in Valve Gear for Locomotive and other Steam Engines.

to actuate the valve of the central cylinder of a three cylinder locomotive engine by means of a pivoted "two-to-one" lever and a floating sway-beam, the sway-beam being arranged transversely of the engine and connected at its ends respectively to the valve spindles of the outer cylinders and being pivoted at its centre to the end of the shorter arm of the "two-to-one" lever which works in a vertical plane and has a fixed pivotal point, the end of the longer arm of said lever being connected to the valve spindle of the central cylinder. 5

Having now particularly described and ascertained the nature of my said invention and in what manner the same is to be performed, I declare that what I claim is:— 10

1. In a steam engine having two outer cylinders and one intermediate or central cylinder, the combination with the distribution valves of the outer cylinders and the valve gears of these valves, of a pivoted lever working about a fixed point on the engine frame and having a longer and a shorter arm, the longer arm being operatively connected at or adjacent its end to the valve spindle of one of the outer cylinders, and a floating lever or sway-beam connected at or adjacent its ends respectively to the valve spindle of the other outer cylinder and to the valve spindle of the intermediate or central cylinder, said floating lever or sway-beam being pivotally connected at its centre to the shorter arm of the other lever at or adjacent the end of said arm, whereby the requisite movements are given to the valve of the intermediate or central cylinder by the movements of the valves and valve gears of the outer cylinders. 15 20

2. In a steam engine having three cylinders the pistons of which are connected to cranks set at 120° to each other on the crank shaft, means operatively connecting the spindle of the distribution valve of the intermediate or central cylinder with the valve spindles, or valve gears, of the distribution valves of the two outer cylinders the said means comprising a two-to-one lever working about a fixed point and having its longer arm operatively connected to the valve spindle of one of the said two outer cylinders and its shorter arm operatively connected to the middle point of a floating lever one end of which is operatively connected to the valve spindle of the other of said two outer cylinders and the other end of which is operatively connected with the valve spindle of the intermediate or central cylinder. 25 30

3. Apparatus of the kind claimed in Claim 1, or in Claim 2, characterised by the fact that the levers are arranged to work in horizontal planes one above the other and are connected to one another and to the respective valve spindles by pins, or pins and links, substantially as described. 35

4. In a steam engine having three working cylinders each with its own distribution valve, the combination, with the valves and the valve gears of the two outer cylinders of two rocking shafts of unequal length, and each working in fixed bearings, means operatively connecting a lever or crank arm at the outer end of the longer rocking shaft with the spindle of the distribution valve of the respective outer cylinder, means operatively connecting a shorter lever or crank arm at the other or inner end of the longer rocking shaft with the centre of a floating sway beam or lever one end of which is operatively connected with the spindle of the distribution valve of the central cylinder, means operatively connecting the other end of the said floating lever with an arm at the inner end of the shorter rocking shaft, and means operatively connecting a corresponding arm at the other or outer end of the shorter rocking shaft with the spindle of the distribution valve of the other outer cylinder. 40 45 50

5. In a steam engine having three working cylinders each with its own distribution valve and valve motion mechanisms or gears one for each of the two outer cylinders, mechanism, for actuating the distribution valve of the intermediate or central cylinder by the movements of the distribution valves and valve gears of the said outer cylinders, the said mechanism having its parts constructed, combined and adapted to operate substantially as described with 55

Improvements in Valve Gear for Locomotive and other Steam Engines.

reference to and illustrated by Figs. 1, 2 and 3 or by Figs. 4, 5 and 6 of the accompanying drawings for the purposes set forth.

Dated this 8th day of May, 1916.

5

JOHN P. O'DONNELL,
Fel. Chart. Inst. P.A., M. Inst. C.E.,
Agent for Applicant,
Palace Chambers, Westminster, S.W.

Redhill: Printed for His Majesty's Stationery Office, by Love & Malcomson, Ltd.—1916.

EXTENSION OF PATENT.

The term of the Patent No. 15769, A.D. 1915, has been extended so as to expire on the thirty-first day of December, 1934, by Order of the High Court.

THE PATENT OFFICE,

18th November, 1931.

D G 1866 - 2 - 125 K A

Fig. 1.

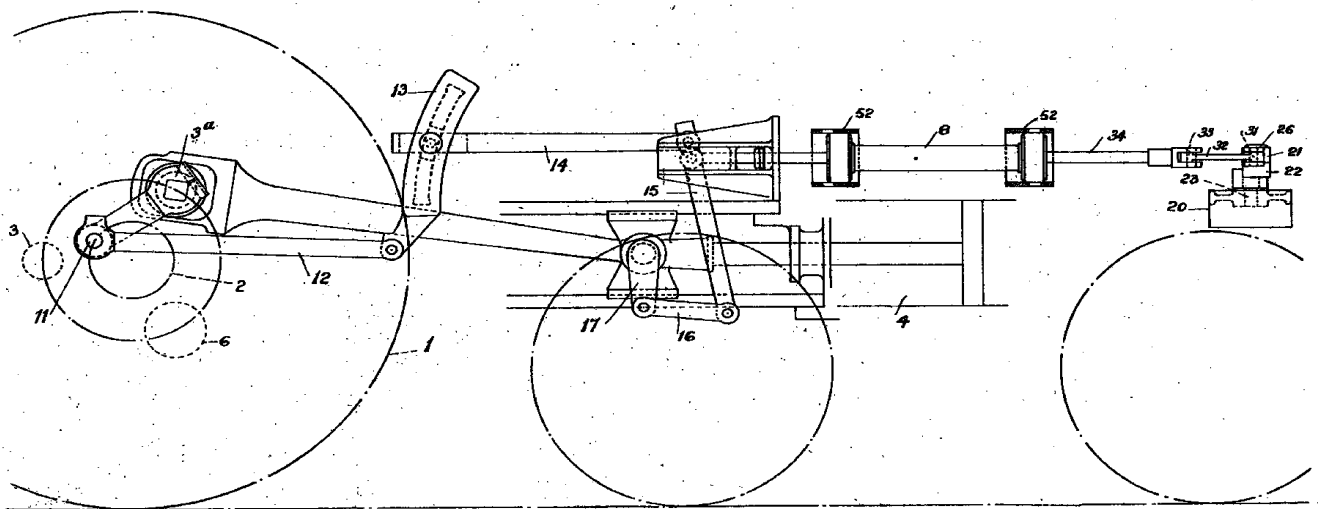

[This Drawing is a reproduction of the Original on a reduced scale.]

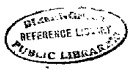
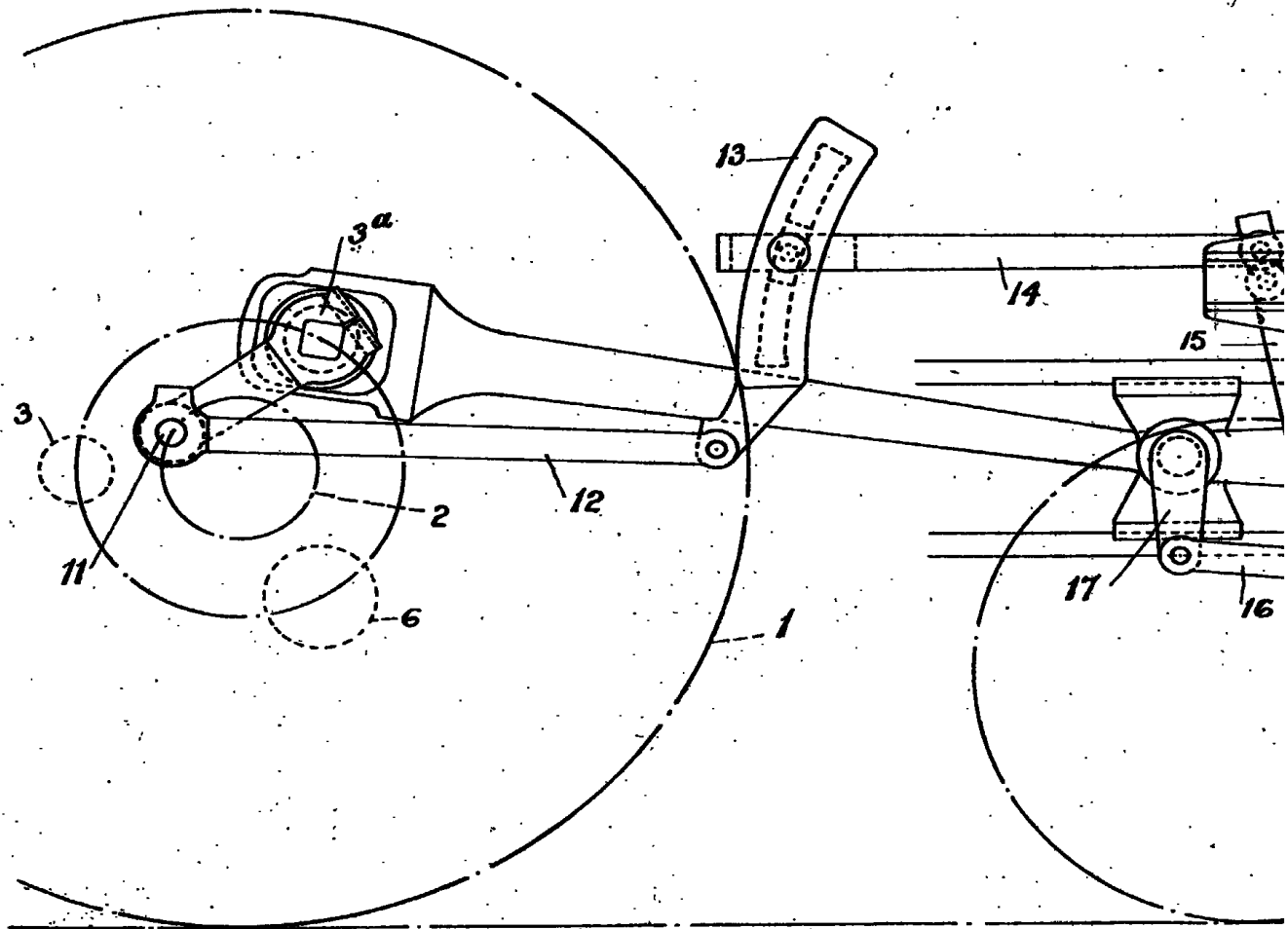

Fig. 1.

[This Drawing is a reproduction of the Original on a reduced scale.]



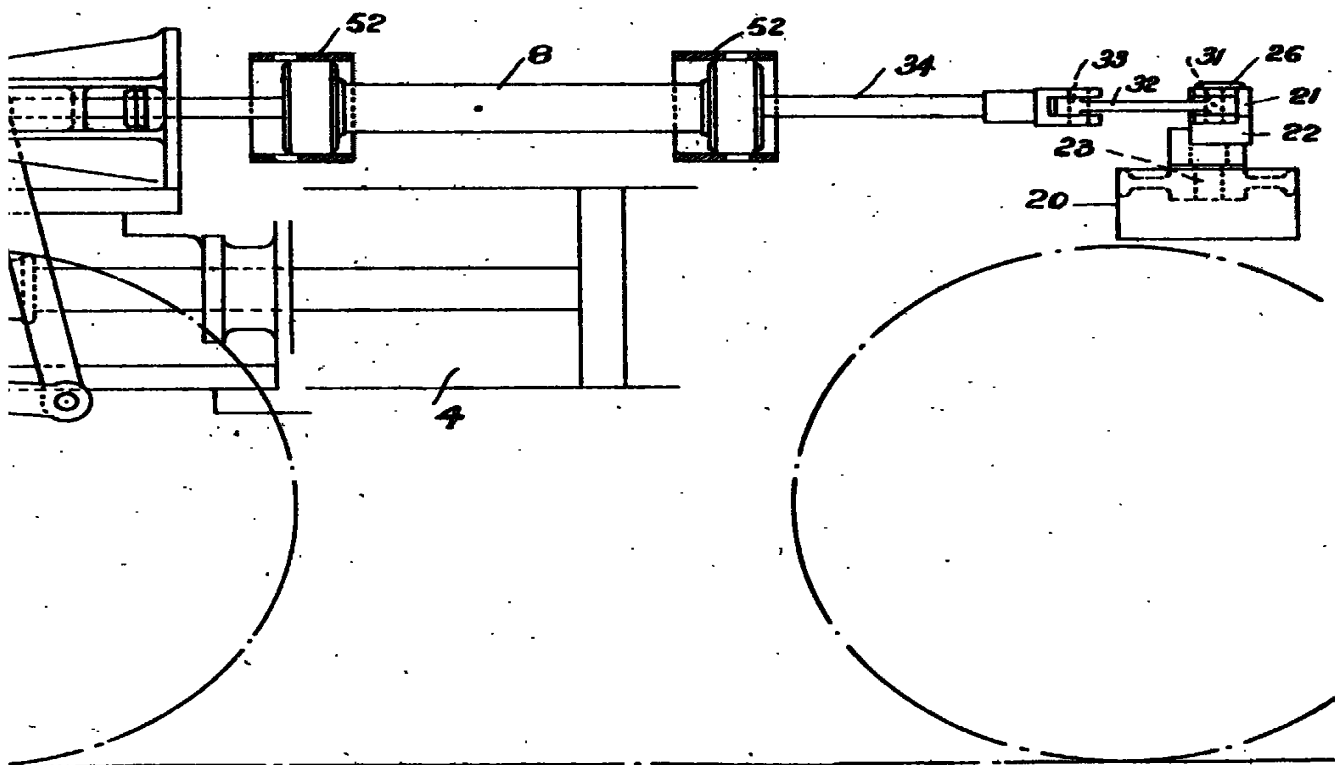
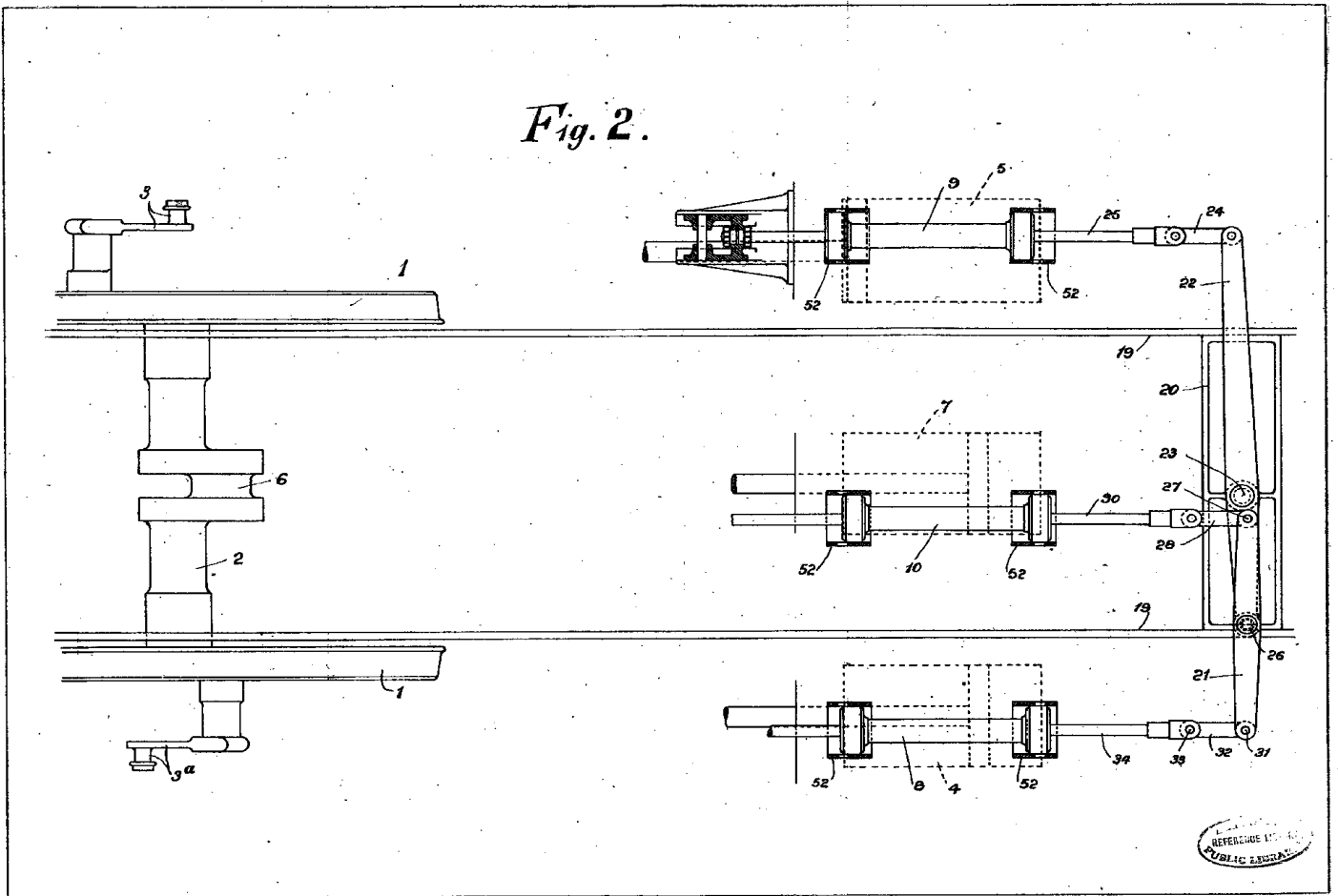

DIAGRAM
REFERENCE LIBRARY
PUBLIC LIBRARY

Fig. 2.

[This Drawing is a reproduction of the Original on a reduced scale.]



RESEARCH INSTITUTE
PUBLIC LIBRARY

Fig. 2.

[This Drawing is a reproduction of the Original on a reduced scale.]

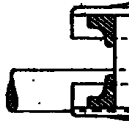
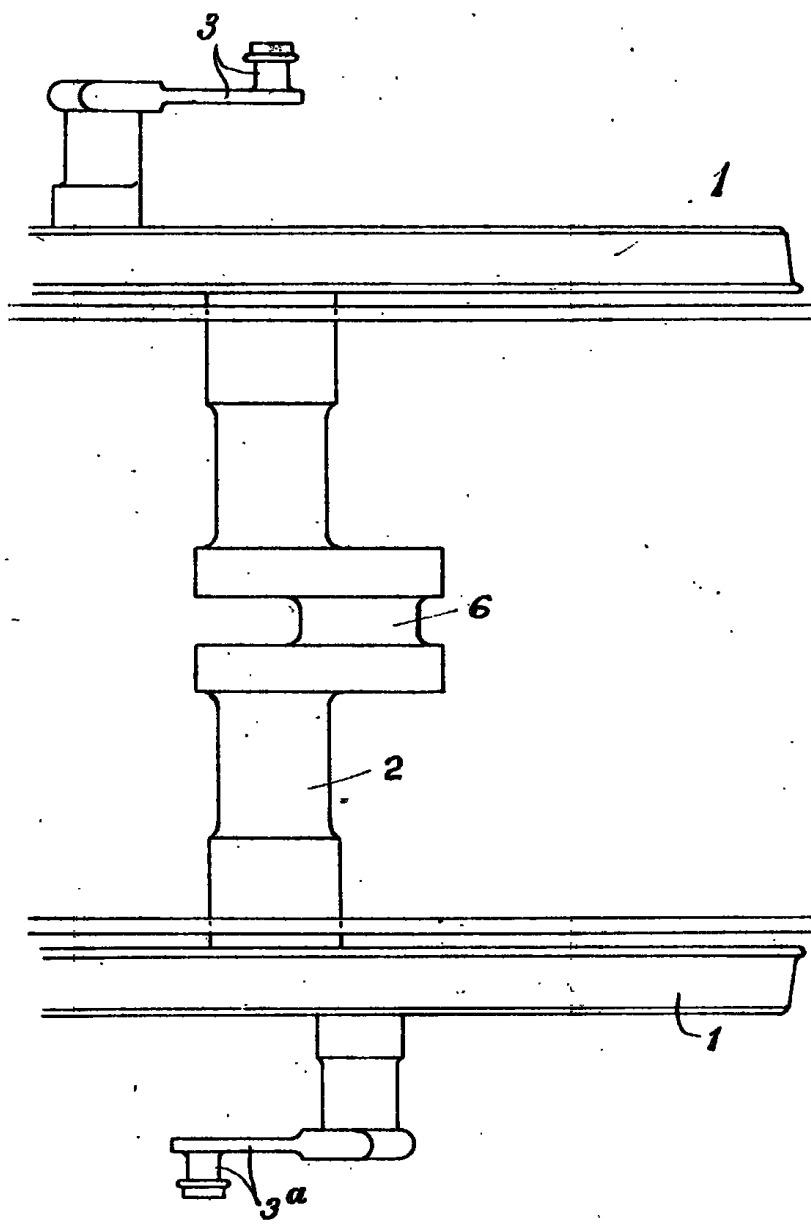

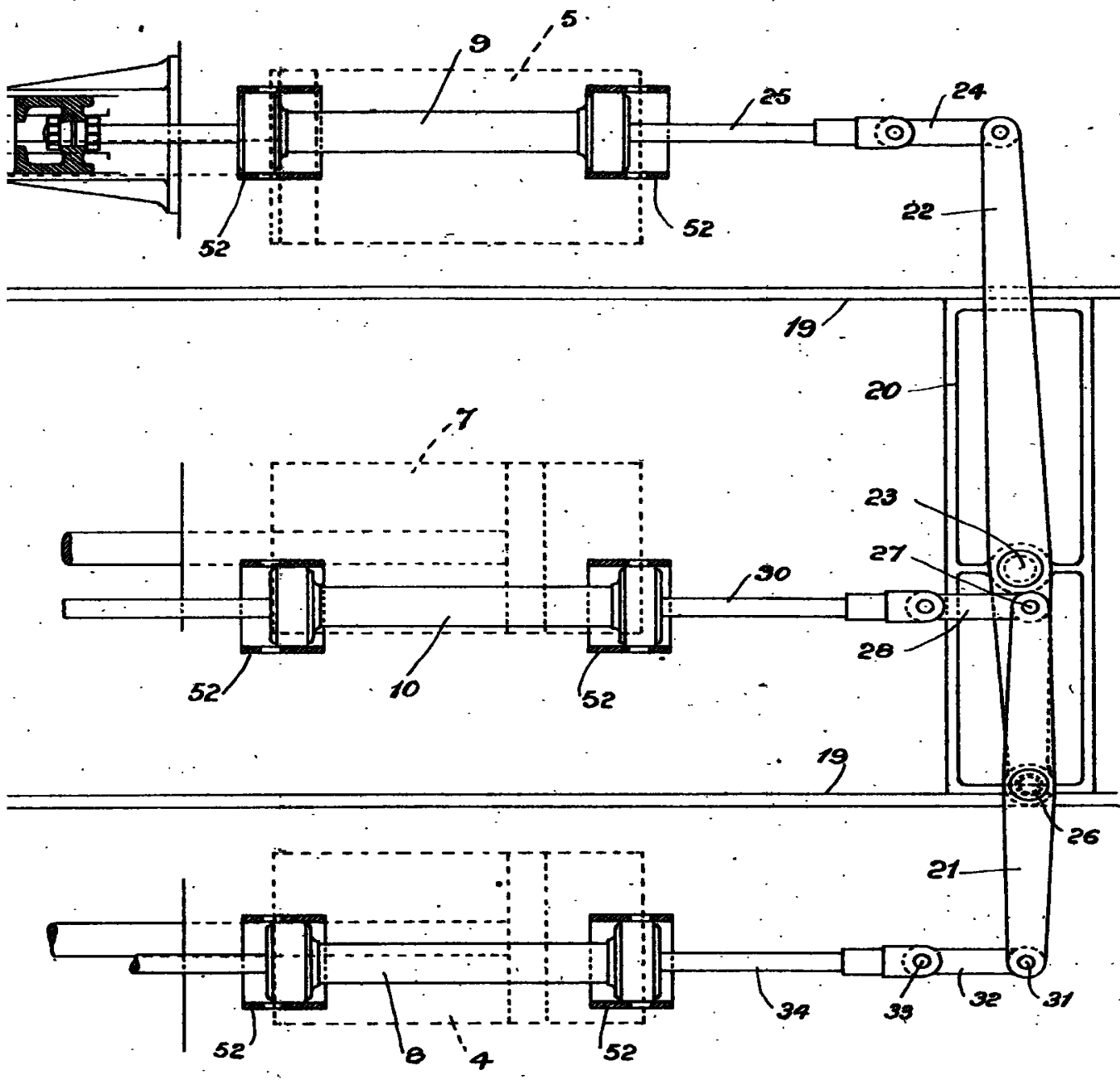

LIBRARY
REFERENCE LIBRARY
PUBLIC LIBRARY

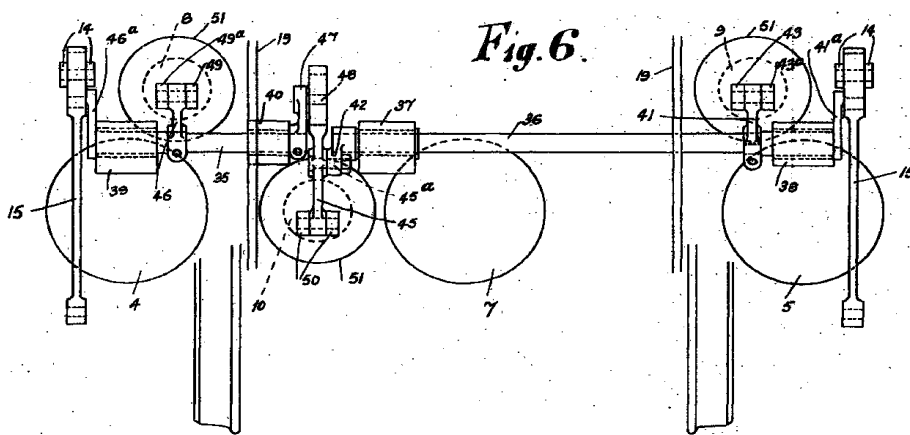

Fig. 6.

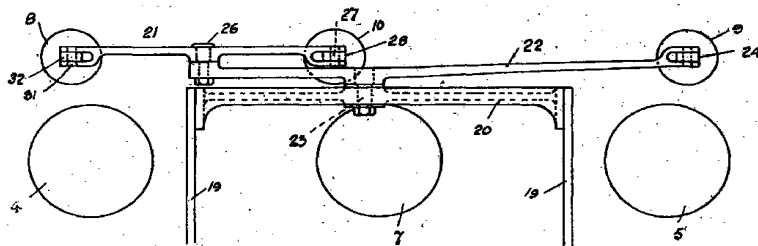

Fig. 3.



[This Drawing is a reproduction of the Original on a reduced scale]

[This Drawing is a reproduction of the Original on a reduced scale.]

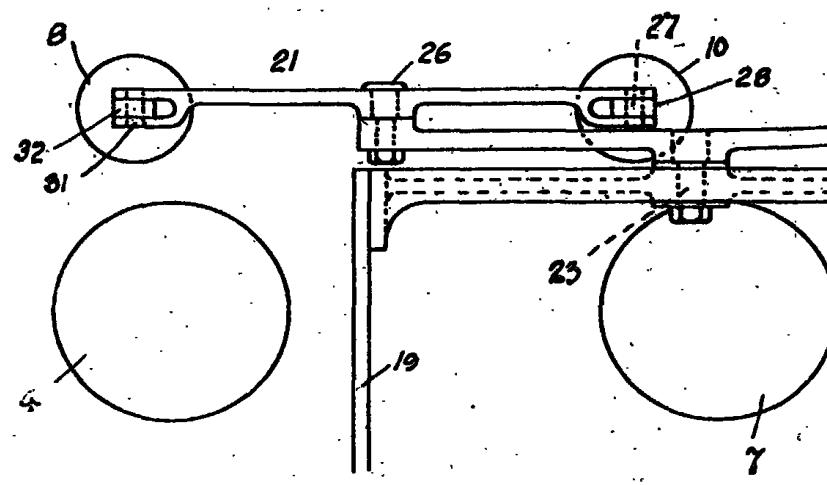
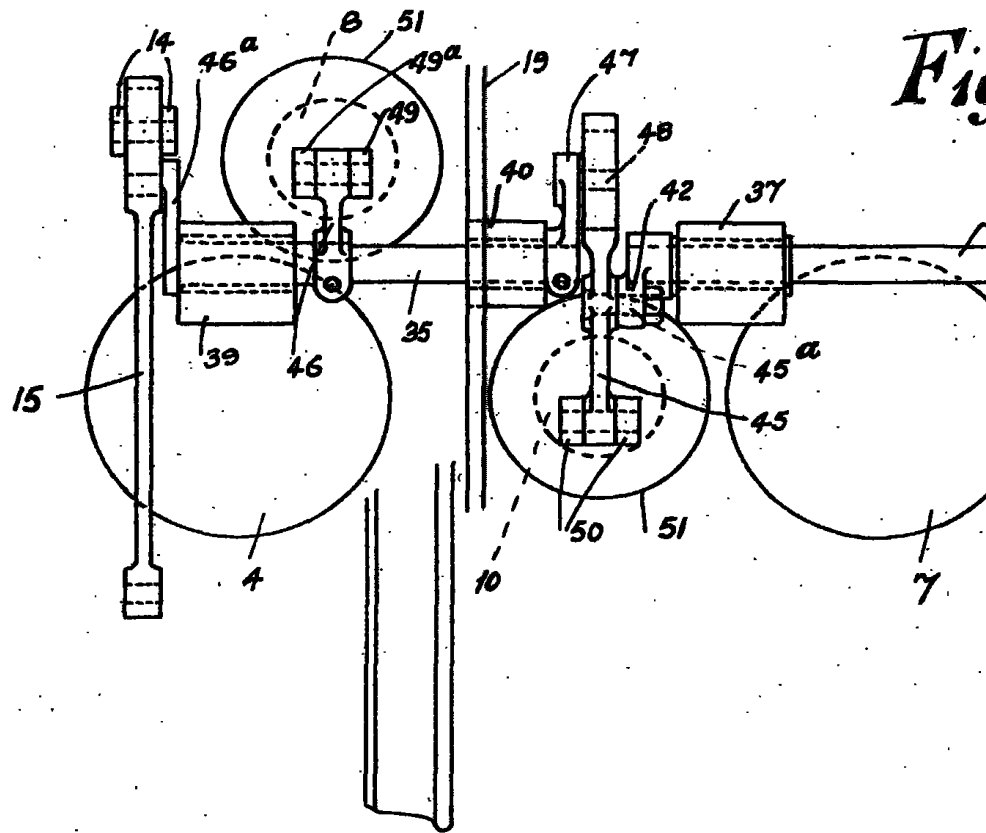

Fig. 6.

36

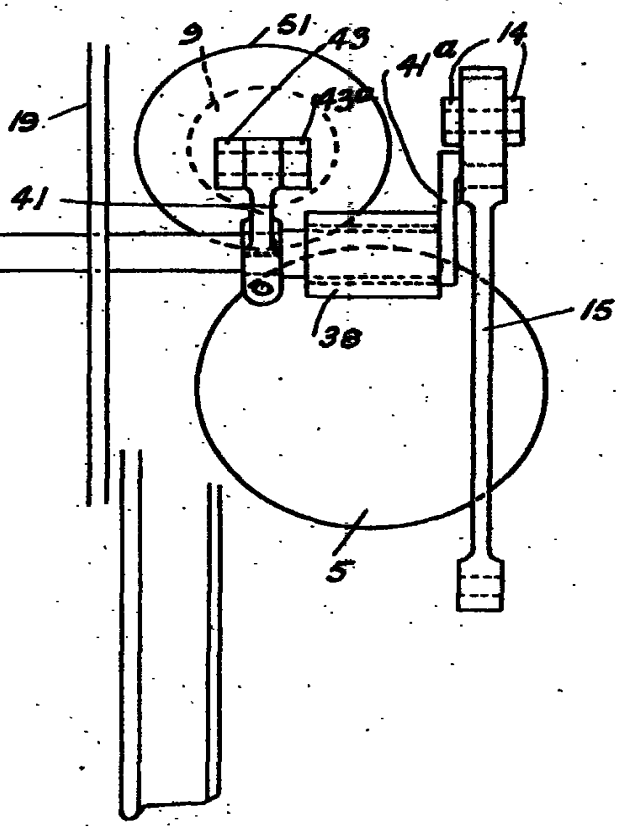
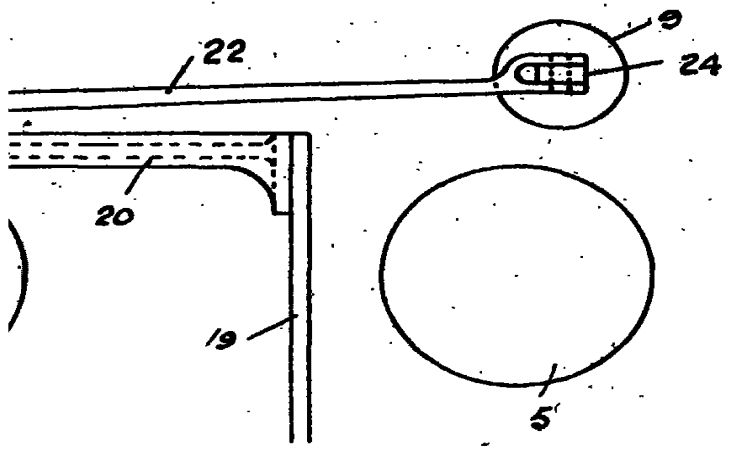
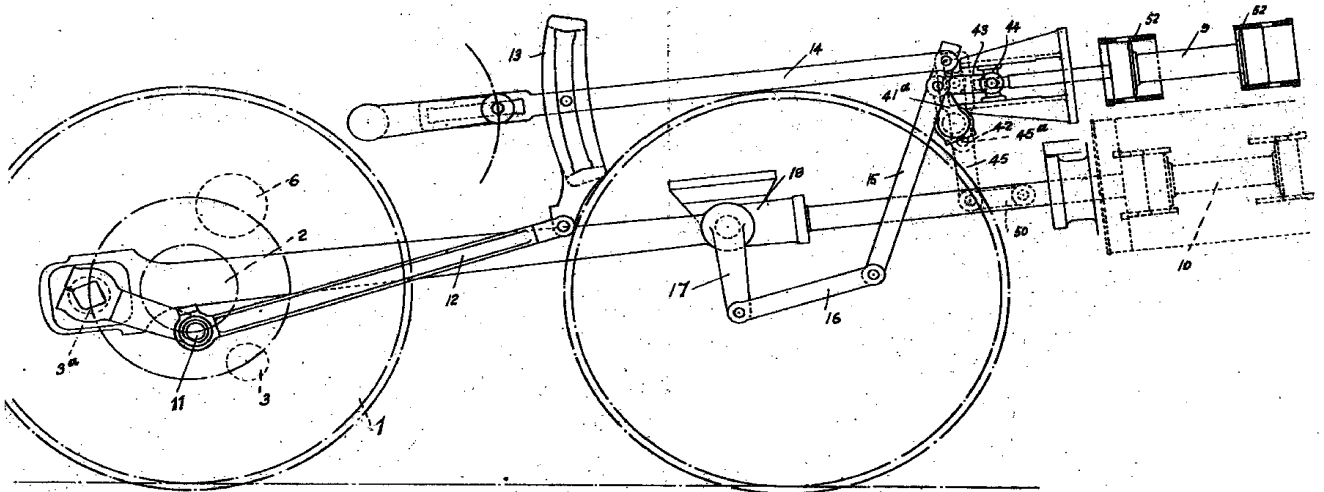

Fig. 3.



BIRMINGHAM
REFERENCE LIBRARY
PUBLIC LIBRARY

Fig. 4.



[This Drawing is a reproduction of the Original on a reduced scale.]



Fig. 1

[This Drawing is a reproduction of the Original on a reduced scale.]

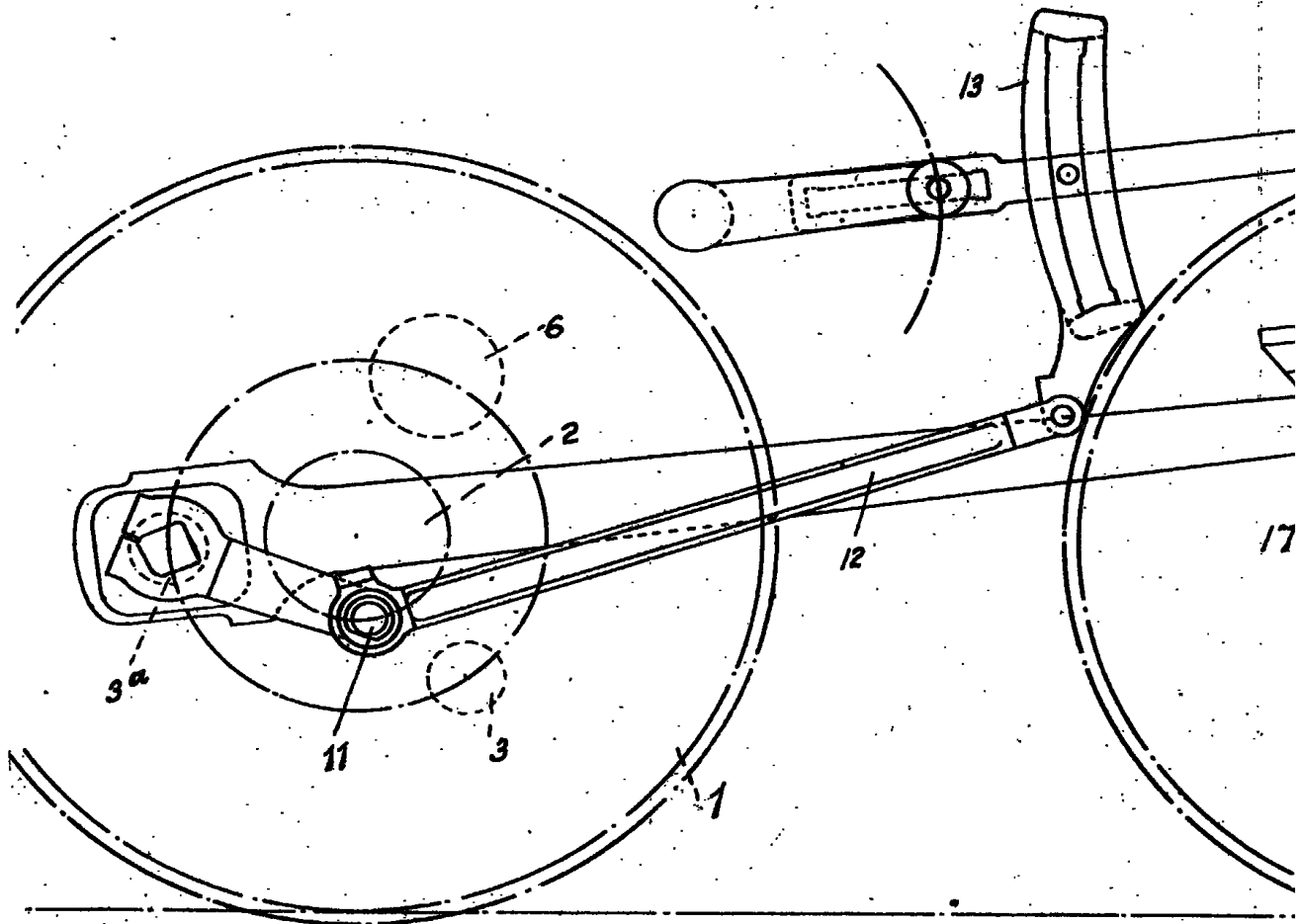

4.

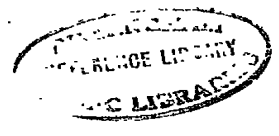
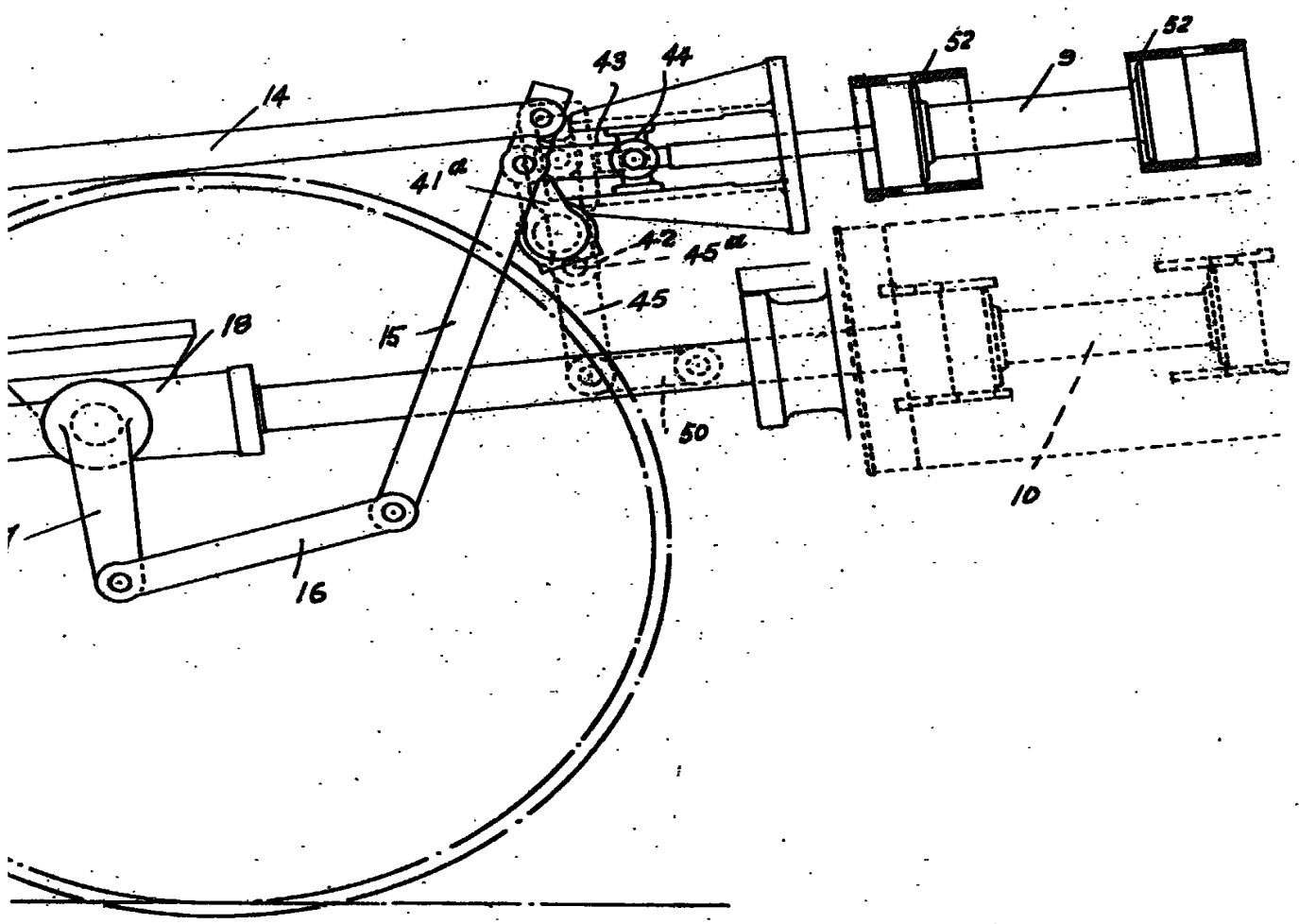
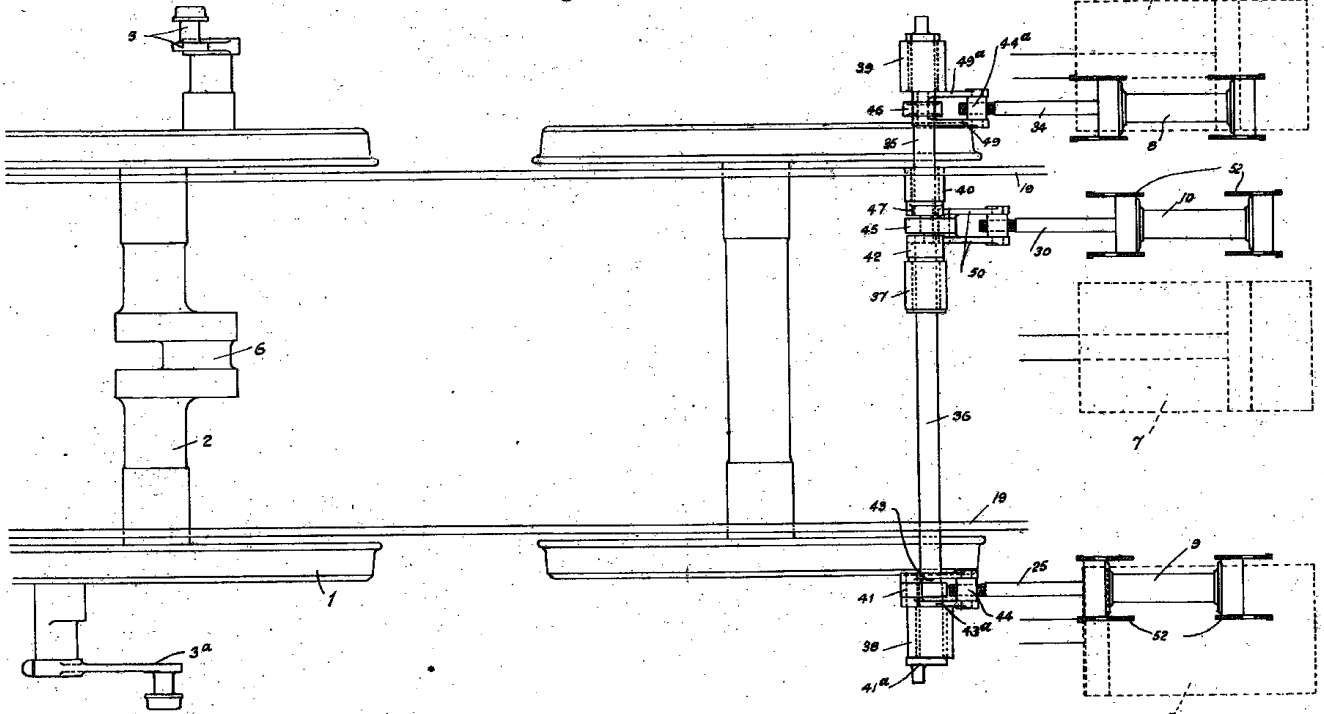

Fig. 5.



[This Drawing is a reproduction of the Original on a reduced scale.]

BRITISH PATENT OFFICE
REFERENCE LIBRARY
PUBLIC LIBRARY

Fig. 5.

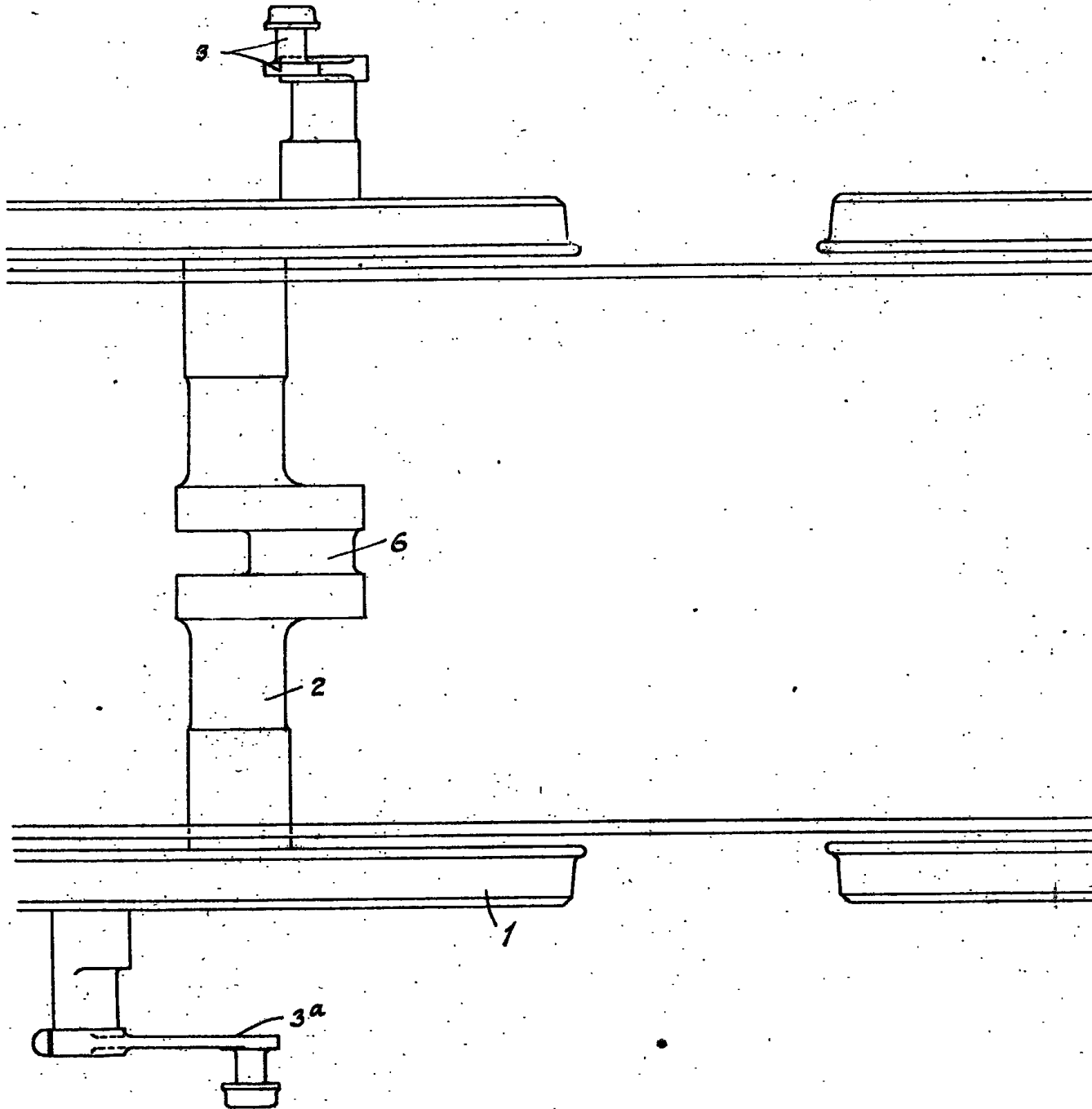

[This Drawing is a reproduction of the Original on a reduced scale.]

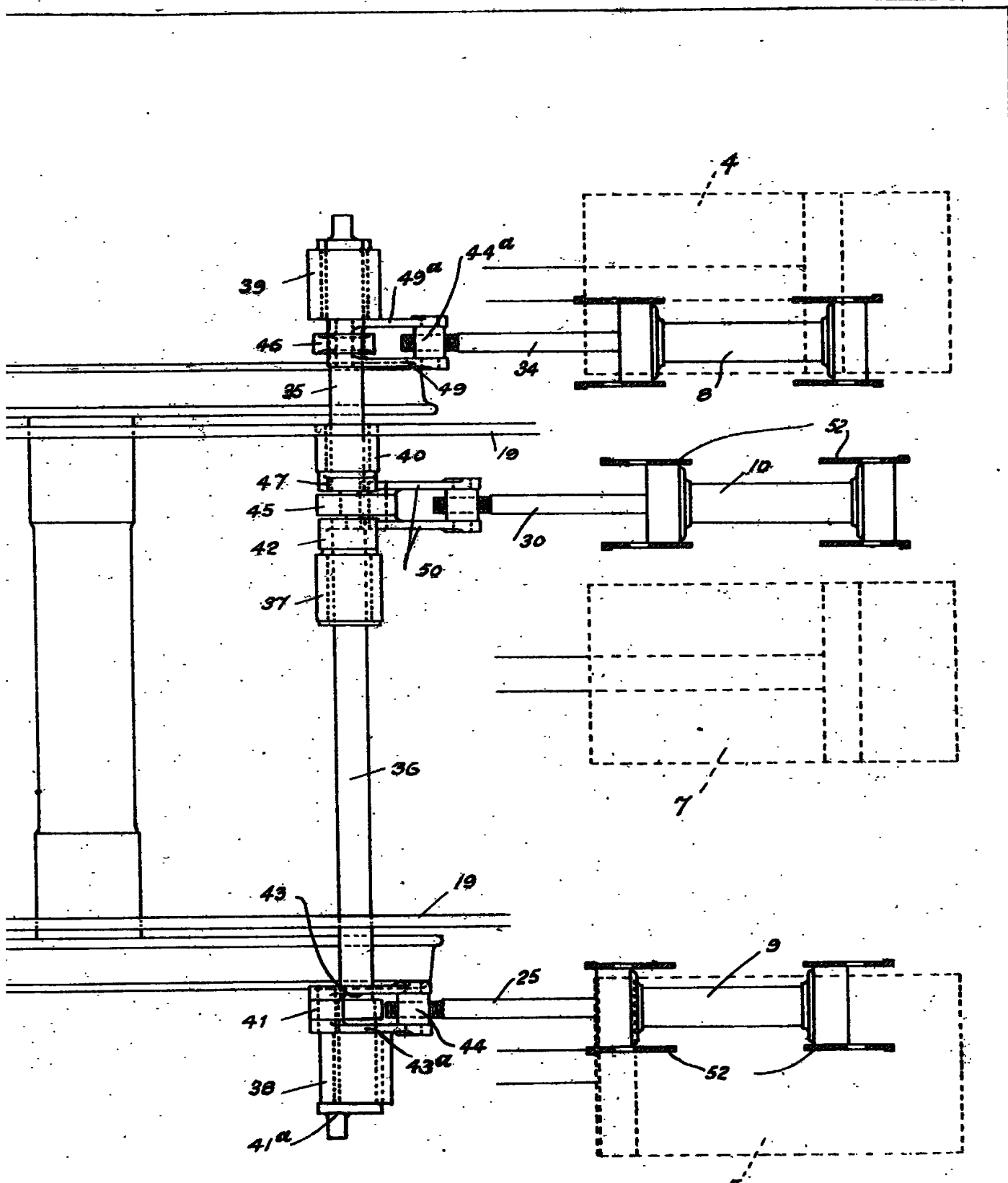

BIRMINGHAM
REFERENCE LIBRARY
PUBLIC LIBRARY